

ATEKO a.s.

1949 – 2019

*A Company Introduction
Gas Drying Technology*

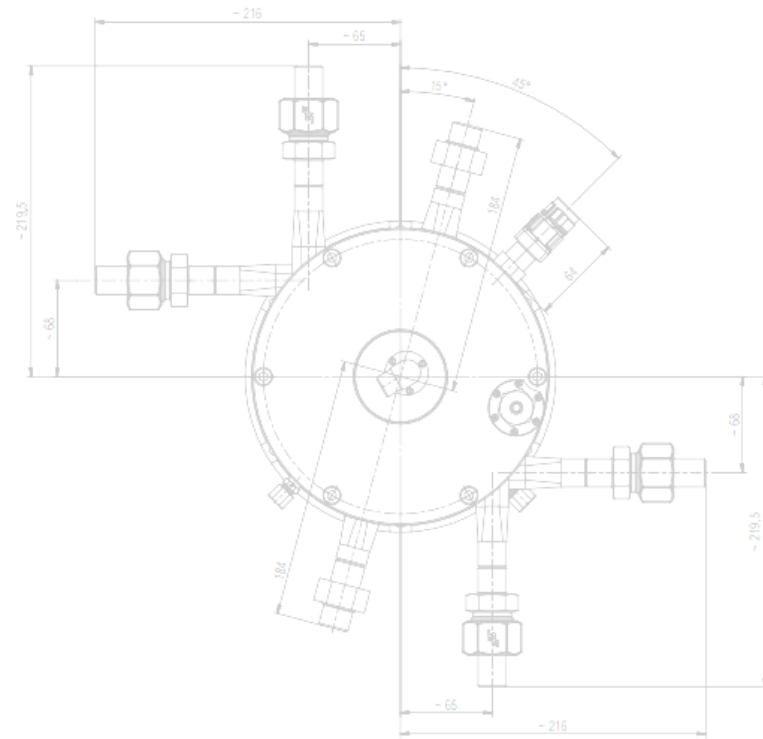

ATEKO a.s.

- **ATEKO a.s.** is an engineering, manufacturing and supply company, offers turn-key deliveries of complete investment plants in the field of:
 - Chemical, gas & oil, energy and food industry
 - Low temperatures, power production technologies
 - Environmental protection technologies.
- Czech company
- Founded in 1949 as a research institute
- Since 1994 ATEKO a.s. (a joint-stock company)
- Company headquarters: Hradec Kralove
- Number of employees: approx. 50
- Share of exports: 30-45 %
- Member of MEDIS Group
- EN ISO 9001:2015
- EN ISO 14001:2015



ATEKO a.s. Business Profile

ATEKO a.s. is an engineering company and specialized supplier that offers deliveries of turnkey industrial plants, technology equipment and numerous services for the chemical, gas & oil, energy, engineering and manufacturing industry.

Portfolio of products and services

- » **Design and engineering services**
 - Civil engineering and design
 - Design of processes and technological plants
 - Design and construction of technological apparatuses, machinery and equipment
 - Designer's and technical supervision
 - Investment consultancy
- » **Technological supplies**
 - Equipment – exchangers, separators, columns, filters, tanks, vessels etc.
 - Machinery – compressors, turboexpanders and expanders
 - Compact technological systems – skids
 - Prototypes and experimental equipment
- » **Construction and civil engineering**
 - Industrial plants
 - Technology plants

Market segments

- **Chemical and petrochemical industry**
- **Gas & oil industry**
- **Automotive and machinery industry**
- **Research centers**
- **Energy sector**

Internal organization

- Business Unit „Advanced Technology & Equipment“**
- Business Unit „Plant Design & Construction“**

Gas Drying Technology – Technological Options

Absorption technology

- Humidity absorption into liquid triethylene glycol (TEG)
- The process is held in absorption column
- Continuous TEG regeneration by distillation of water in regenerator (up to 200°C)

Adsorption technology

- Humidity absorption on solid adsorbent – silicagel, alumina or molecular sieve
- The process is held in periodically working adsorbers – cycle phases adsorption, heating, regeneration and cooling
- Adsorbent regeneration is done by heated gas (min 150°C)

Low-temperature separation

- Humidity condensation by low-temperature and subsequent separation on gas-liquid mixture
- Convenient use of „jet-effect“, ie. temperature decline due to expansion
- Methanol, DEG injection – protection against hydrate formation
- Cold regeneration

Gas Drying Technology – General Data

Typical Operating Data:	Filtration:	Drying:
Capacity:	100 000 – 300 000 Nm ³ / hour	100 000 – 300 000 Nm ³ / hour
Pressure:	7 – 20 MPa	6 – 10 MPa
Temperature:	+3 °C – +40 °C	+15 °C – +25 °C
Filtration Efficiency:	20 micro meters	
Dew Point:		-7 °C at 4 MPa as minimal

Gas Drying Technology - Deliveries

ATEKO Capabilities:

- Turn-key Solutions
- Plant Projects
- Technology Design
- Individual Apparatuses
 - *both of design and manufacture*
 - *Separators*
 - *Absorption Columns*
 - *Heat Exchangers*
 - *Regeneration Units*
 - *Filters incl. filter elements*
 - *On-site supervision*
- Accessories delivery

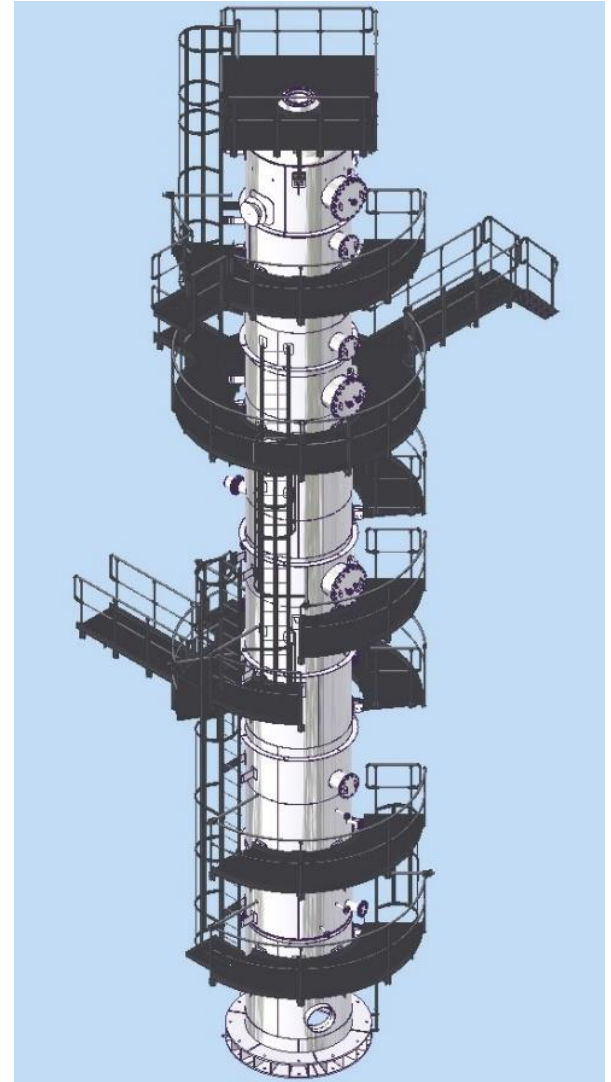

Gas Drying Technology – TEG Operating Scheme (1)

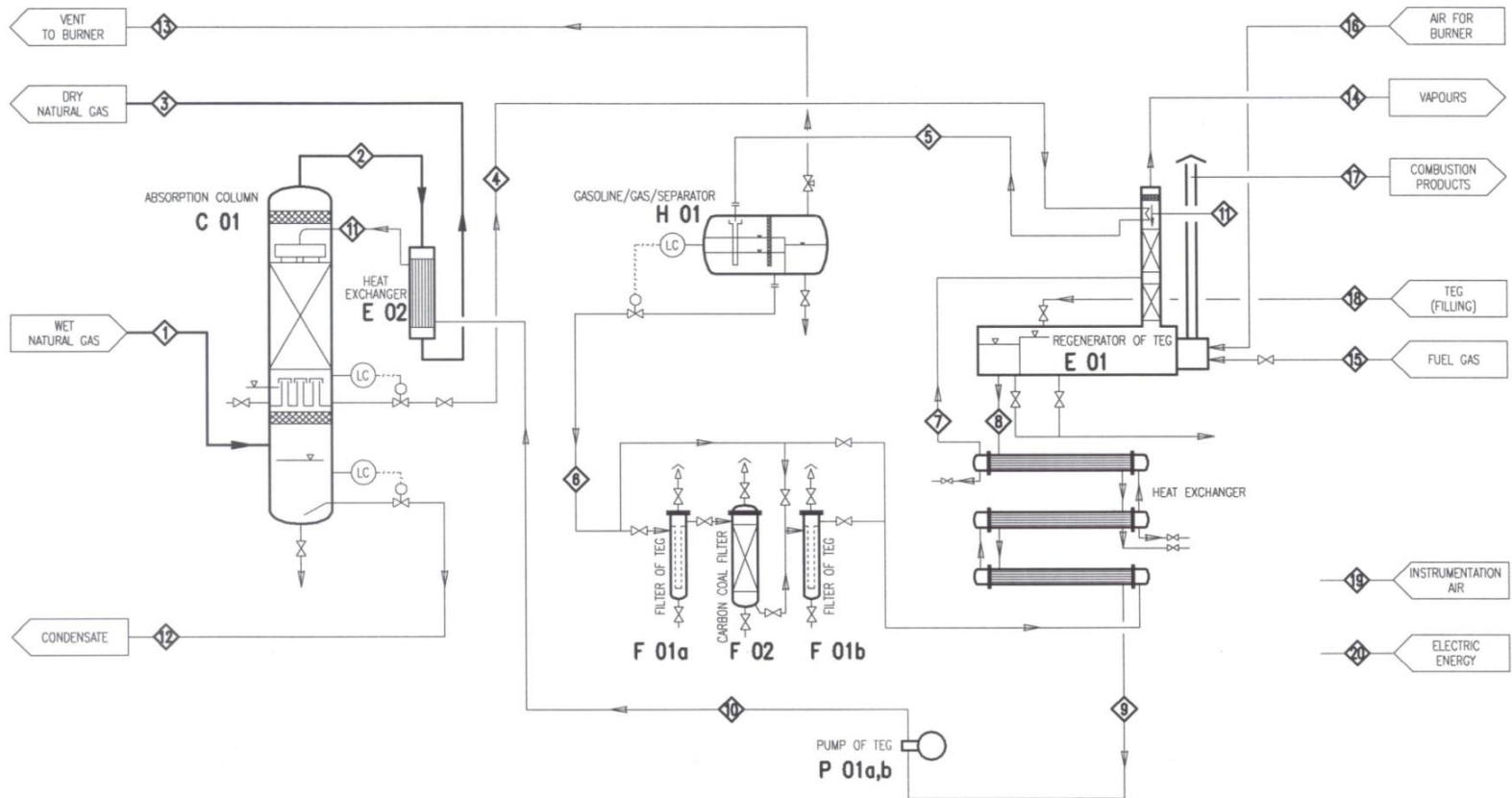

Gas Drying Technology – TEG Operating Scheme (2)

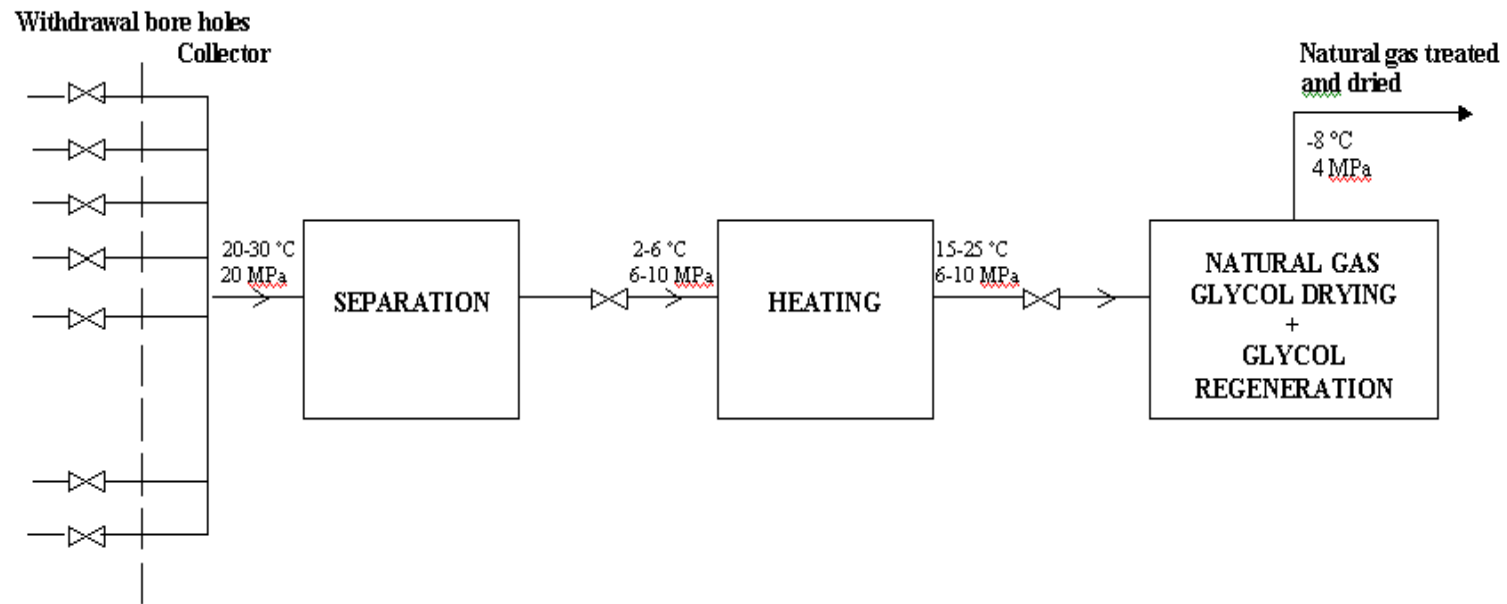

Gas Drying Technology – References 2018

innogy Gas Storage, UGS Štramberk, CZ – Gas Drying Equipment (Gas drying columns, TEG Regeneration Unit, Breed Vapours Combustion Unit)



Gas Drying Technology – References 2018

innogy Gas Storage, UGS Štramberk, CZ - under development, a complete technology to be delivered



Gas Drying Technology – References 2017

innogy Gas Storage, UGS Hájce, CZ – Emission Limits and TEG Regeneration

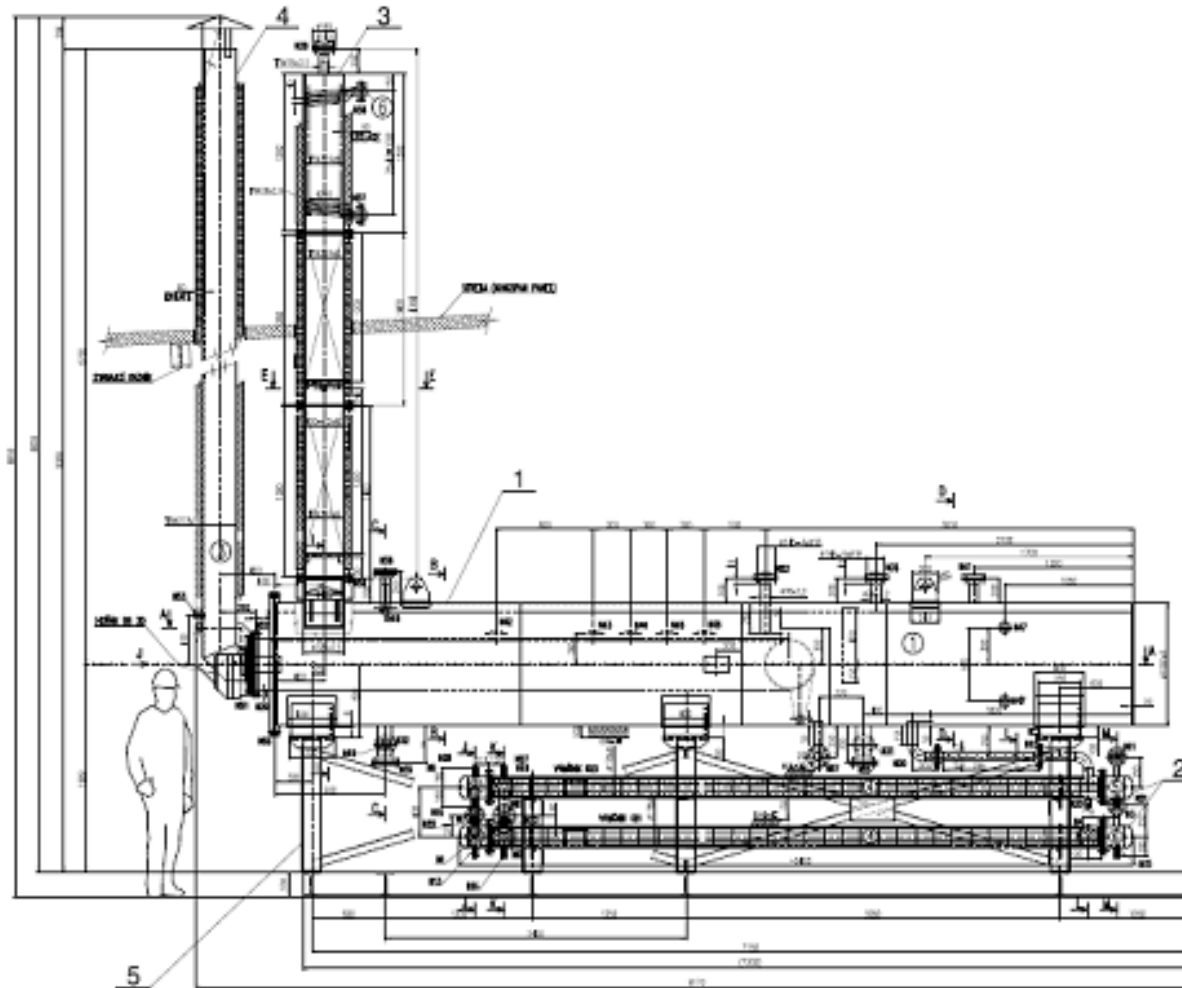

Gas Drying Technology – References 2016

RWE Gas Storage, UGS Třanovice, CZ, Low Pressure Gas Drying



Gas Drying Technology – References 2015

RWE Gas Storage, UGS Dolní Dunajovice, Filterseparators for Natural Gas



Gas Drying Technology – References 2014

NAFTA, UGS Gajáry, SK, Enerflex Separator Overhaul, A New Gas Heater



Gas Drying Technology – References 2013

RWE Gas Storage, UGS Háje, CZ, Technology Repair and Refurbishment



Gas Drying Technology – References 2012

Plynostav, Powerplant Počerady, CZ, Filterseparators, Filters, Special Heaters



Gas Drying Technology – References 2011

RusGasEngineering Company, Russia, UGS Uhřice, CZ, Audit of the project implementation documentation

Assessment of the project and realization documentation for the construction of a new unit of the natural gas low temperature drying for underground storage NG Uhřice

Gas Drying Technology - References 2010

Plynostav, CZ, UGS Wierzchowice, PL, Design, manufacture, delivery of gas filterseparator with quick-closure, 13 pcs

Design of UGS Wierzchowice,

- main stage $3,5 \cdot 10^9 \text{ Nm}^3$,
- sub-stage $1,2 \cdot 10^9 \text{ Nm}^3$



Gas Drying Technology - References

***A deep history because of
many projects since 1976 ...***

Thank you for your attention

<http://www.ateko.cz>

ateko@ateko.cz

